

TrAle Ball Valves

2 ways

2 Ways ball valve BSP female with holes

Page: 1/1

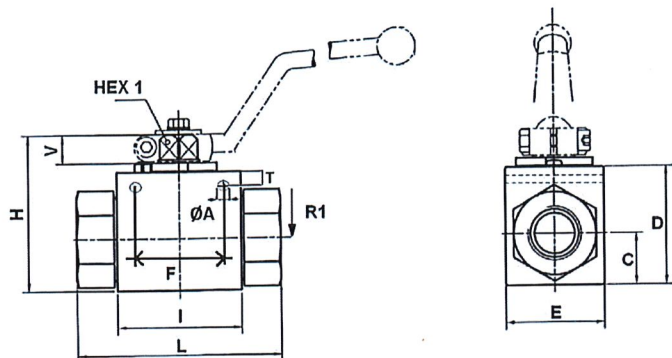

Standard o-ring: NBR

Ball seat: POM
(polyoxymethylene)

Part nº	DN	R1	MAX. PRESSURE (bar)	HEX 1	ØA	C	D	E	F	H	I	L	T	V
GB2V 1/4	6	1/4" BSP	500	9	4,5	13	32	28	26	44,5	37	69	5	8
GB2V 3/8	10	3/8" BSP	500	9	6,5	17	40	32	32	52,5	42	72	5	8
GB2V 1/2	13	1/2" BSP	500	9	6,5	17	40	35	37,5	52,5	48	83	4,8	8
GB2V 3/4	20	3/4" BSP	315	14	6,5	24	57	48	45	75	60	95	6,5	12
GB2V 1	25	1" BSP	315	14	6,5	28,5	64	57	55	82	65	113	6	12

TrAle Ball Valves

2 ways

2 Ways ball valve: tube connection Light Serie

Page: 1/1

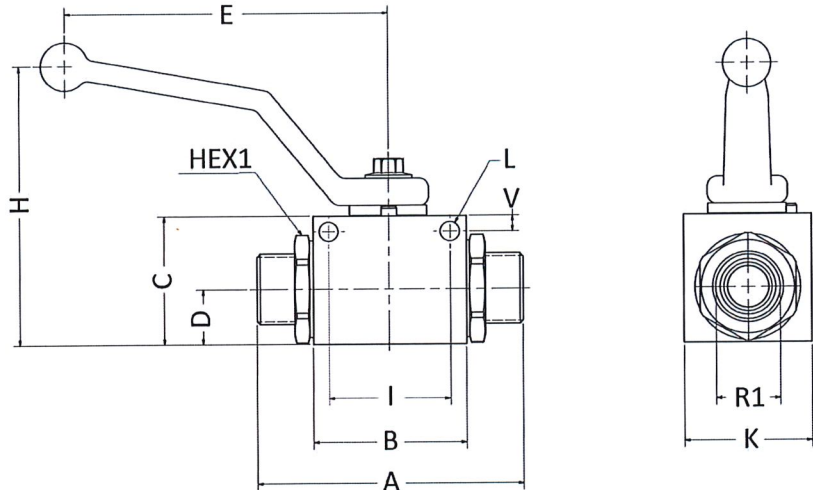
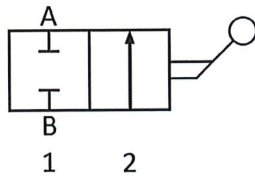
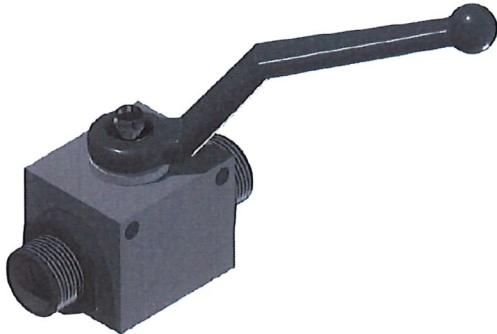

Standard o-ring: NBR

Ball seat: POM
(polyoxymethylene)

Part n°	DN	ØD1	R1	MAX. PRESSURE (bar)	HEX 1	A	B	C	D	E	H	I	K	L	V
GB2V 6 L	6	6L	M12x1.5	500	22	67	37	32	13	110	68	26	28	4,5	5
GB2V 8 L	6	8L	M14x1.5	500	22	67	37	32	13	110	68	26	28	4,5	5
GB2V 10 L	8	10L	M16x1.5	500	27	74	42	40	17	110	77	32	32	6,5	5
GB2V 12 L	10	12L	M18x1.5	500	27	74	42	40	17	110	77	32	32	6,5	5
GB2V 15 L	13	15L	M22x1.5	500	30	82	48	40	17	110	77	37,5	40	6,5	4,8
GB2V 18 L	13	18L	M26x1.5	400	30	82	48	40	17	110	77	37,5	40	6,5	4,8
GB2V 22 L	20	22L	M30x2	315	41	101	60	57	24	170	108	45	48	6,5	6,5
GB2V 28 L	25	28L	M36x2	315	50	108	65	64	28,5	170	115	55	57	6,7	6

TrAle Ball Valves

2 ways

2 Ways ball valve: tube connection Heavy Serie

Page: 1/1

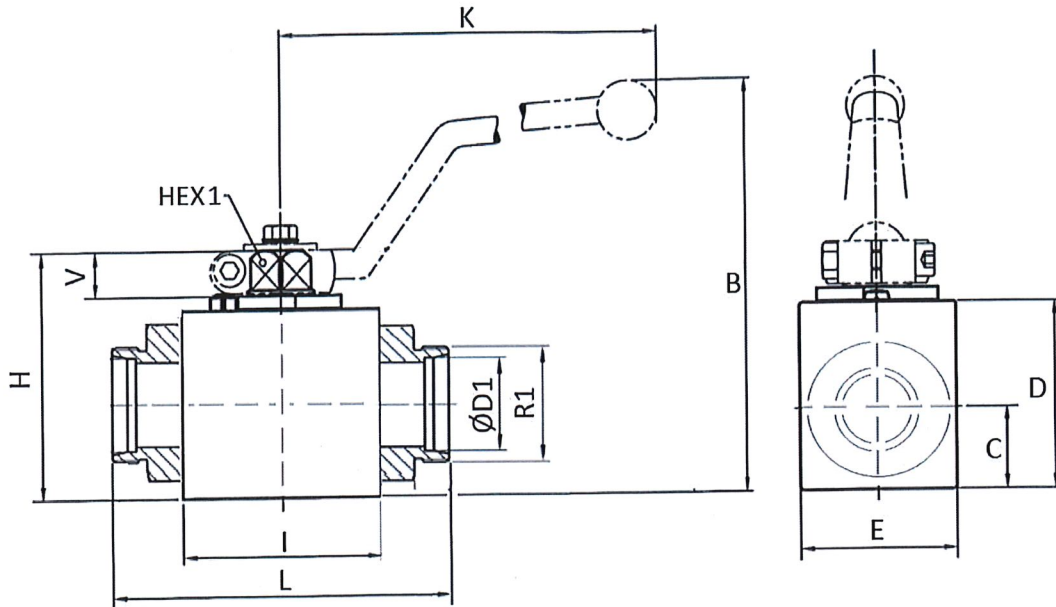

Standard o-ring: NBR

Ball seat: POM
(polyoxymethylene)

Part n°	DN	ØD1	R1	MAX. PRESSURE (bar)	HEX 1	A	B	C	D	E	H	I	K	L	V
GB2V 8 S	4	8S	M16x1.5	500	9	-	82	13,5	33	26	47	40	115	73	11
GB2V 10 S	6	10S	M18x1.5	500	9	-	82	13,5	33	26	47	40	115	73	11
GB2V 12 S	8	12S	M20x1.5	500	9	-	82	13,5	33	26	47	40	115	76	11
GB2V 16 S	13	16S	M24x1.5	500	9	-	89	19	40	35	54	48	115	86	11
GB2V 20 S	16	20S	M30x2	400	9	-	89	19	40	35	54	48	115	90	11
GB2V 25 S	20	25S	M36x2	315	14	79	-	24,5	57	49	75	62	200	109	14
GB2V 30 S	25	30S	M42x2	315	14	87	-	29,5	65	58	83	66	200	120	14

TrAle Ball Valves

3 ways

3 Ways ball valve female-male(60°)-female (L type)

Page: 1/1

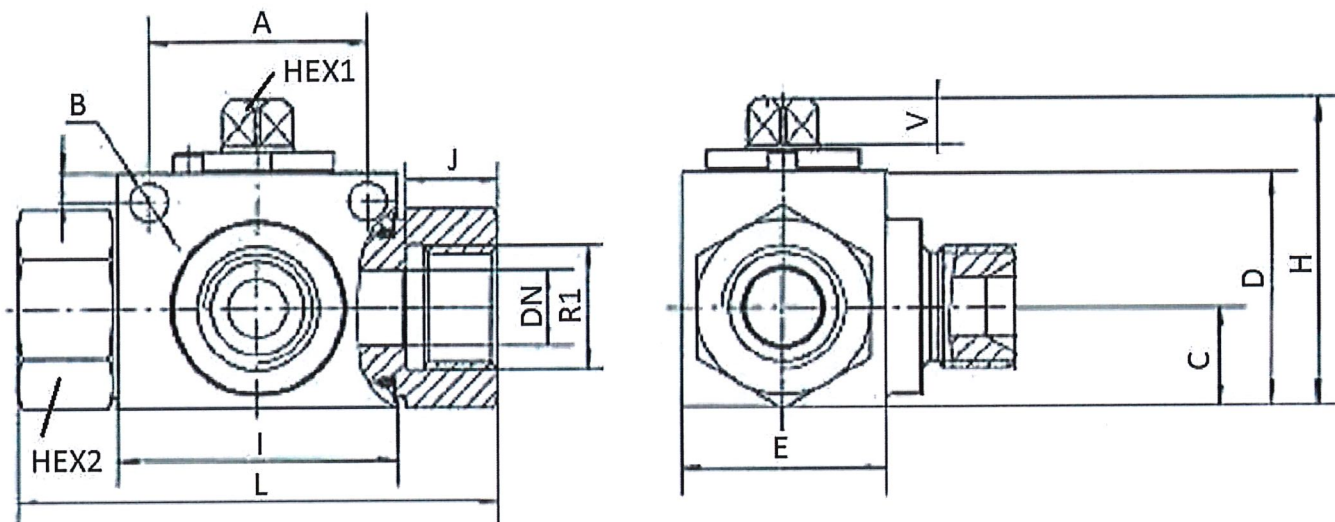

With fixing holes

Standard o-ring: NBR

Ball seat: POM (polyoxymethylene)

Lever included

Part n°	DN	R1	Working Pressure (bar)	HEX 1	HEX 2	ØB	A	C	D	E	H	I	J	L	V
GB3V 1/4	6	1/4" BSP	500	9	22	4,5	26	13	32	28	44,5	37	14	69	8
GB3V 3/8	10	3/8" BSP	500	9	27	6,5	32	17	40	32	52,5	42	14	72	8
GB3V 1/2	13	1/2" BSP	500	9	30	6,5	37,5	17	40	35	52,5	48	16	83	8
GB3V 3/4	20	3/4" BSP	315	14	41	6,5	45	24	57	48	75	60	18	95	12
GB3V 1	25	1" BSP	250	14	50	6,7	55	28,5	64	57	82	65	20,5	113	12

Inlet pressure only allowed by central intake.

TrAle Ball Valves

3 ways

3 Ways ball valve female-female-female (L type)

Page: 1/1

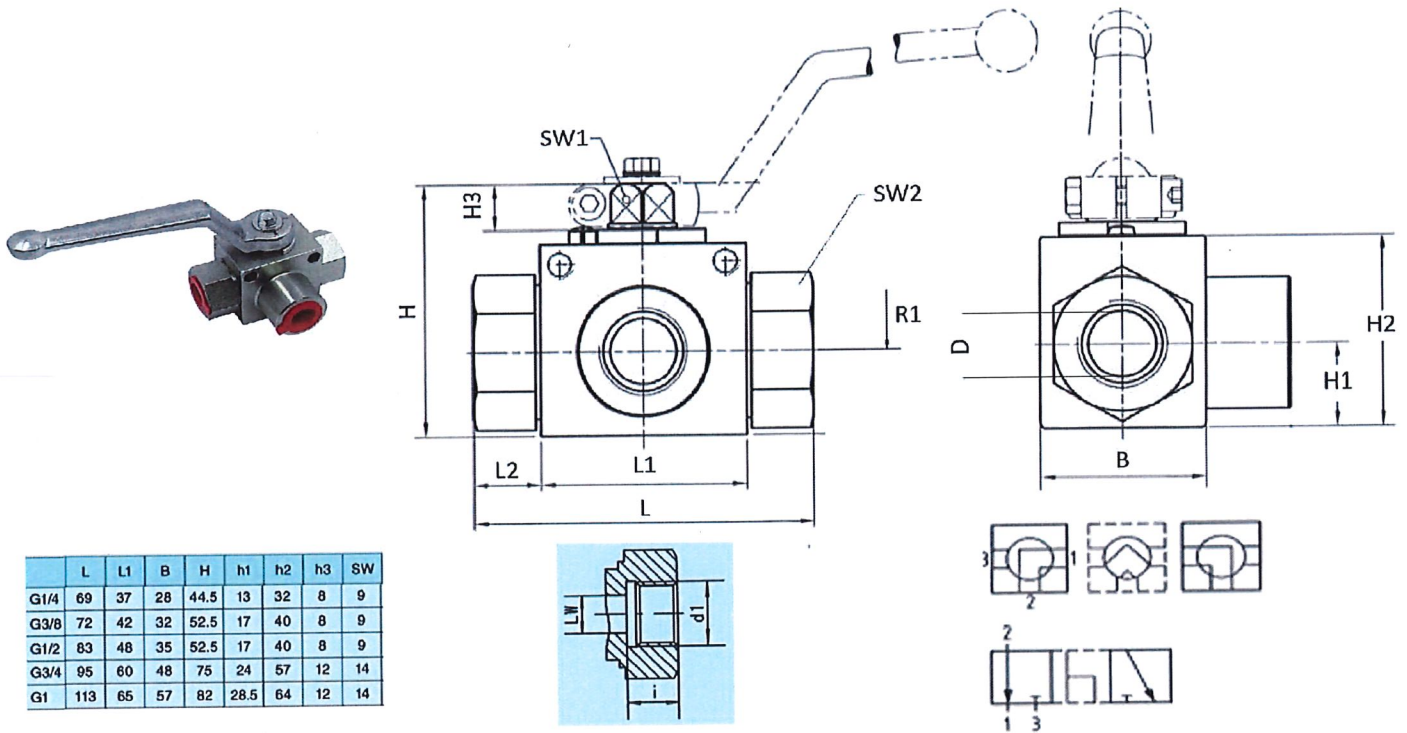

With fixing holes

Standard o-ring: NBR

Ball seat: POM (polyoxymethylene)

Working temp: -20°C / +100°C

Lever included (angular)

Part n°	DN	R1	Working Pressure (bar)	WAYS
GB3VH 1/4	6	1/4" BSP	500	H-H-H
GB3VH 3/8	10	3/8" BSP	500	H-H-H
GB3VH 1/2	13	1/2" BSP	500	H-H-H
GB3VH 3/4	20	3/4" BSP	500	H-H-H
GB3VH 1	25	1" BSP	500	H-H-H

TrAle Ball Valves

2 ways

2 Ways ball valve NPT female

Page: 1/1

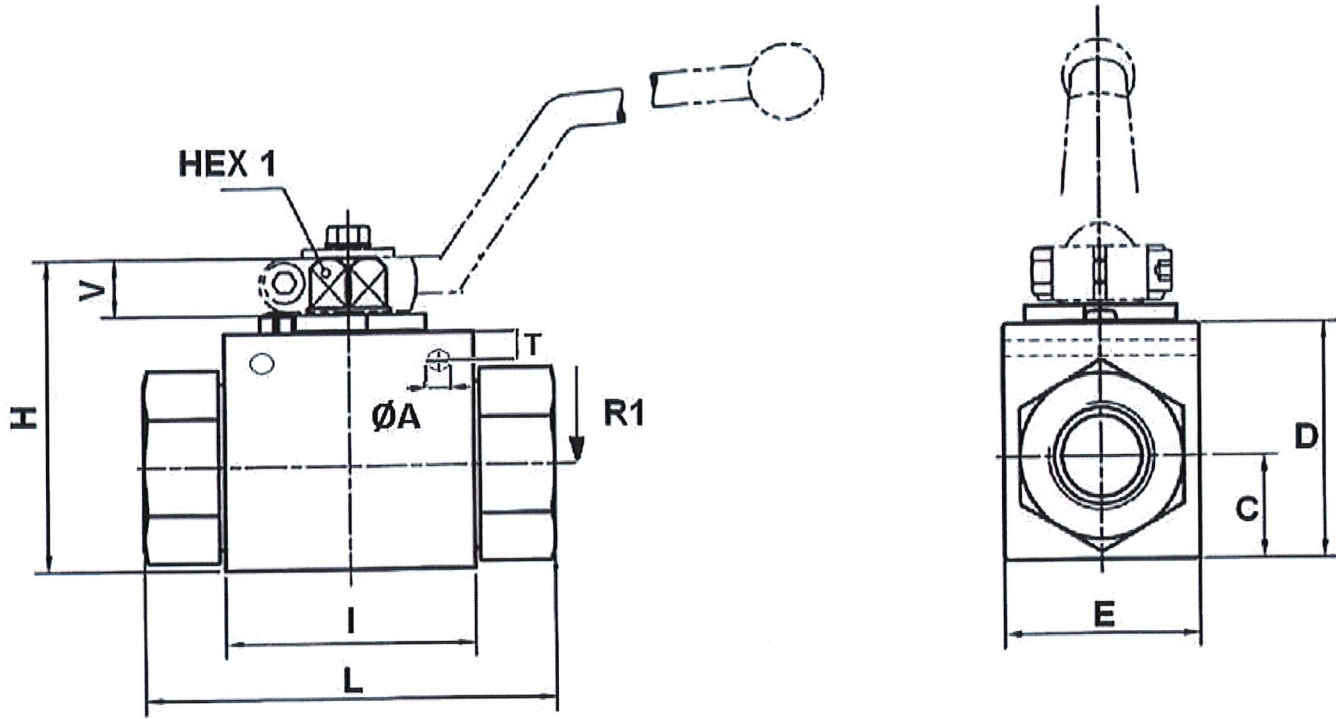

Standard o-ring: NBR
 Ball seat: POM
 (polyoxymethylene)

Part nº	DN	R1	MAX. PRESSURE (bar)	HEX 1	ØA	C	D	E	H	I	L	T	V
GB2V 1/4 NPT	6	1/4" NPT	500	9	4,5	13	32	28	44,5	37	69	5	8
GB2V 3/8 NPT	10	3/8" NPT	500	9	6,5	17	40	32	52,5	42	72	5	8
GB2V 1/2 NPT	13	1/2" NPT	500	9	6,5	17	40	35	52,5	48	83	4,8	8
GB2V 3/4 NPT	20	3/4" NPT	315	14	6,5	24	57	48	75	60	95	6,5	12
GB2V 1 NPT	25	1" NPT	315	14	6,5	28,5	64	57	82	65	113	6	12